

Bob Long's
DEFIANTtm
INSTRUCTION MANUAL
Version 1.0

Copyright 1999
by Indian Creek Design, Inc.

All Rights Reserved

No part of this document may be copied or reproduced in any form or by any means without the prior written consent of **Bob Long, or Indian Creek Design, Inc.**

Notice is hereby given that this manual is part of the article owned in whole by Indian Creek Design, Inc., known as indicated in this manual and drawings. All rights of manufacture and reproduction of such articles or any part thereof are reserved by Indian Creek Design, Inc. Neither said article nor any part thereof may be manufactured or reproduced except by written authorization from Indian Creek Design, Inc. All proprietary rights and information are the sole property of Indian Creek Design, Inc.

STATEMENT OF LIABILITY

This air gun is delivered by **Indian Creek Design, Inc. and B.L.A.S.T, Inc.**, with the understanding that **Indian Creek Design, Inc. and B.L.A.S.T, Inc.**, assumes no responsibility for its resale or safe handling. It can be considered a dangerous weapon if mishandled, abused, or the safety instructions are ignored. **Indian Creek Design, Inc. and B.L.A.S.T, Inc.**, assumes no responsibility for physical injury or property damage resulting from its use.

Indian Creek Design, Inc. and B.L.A.S.T, Inc., makes no warranties with respect to this documentation and disclaims any implied warranties of merchantability or fitness for a particular purpose. The information in this document is subject to change without notice. **Indian Creek Design, Inc. and B.L.A.S.T, Inc.**, assumes no responsibility for any errors that may appear in this document.

WARNING:

This is not a toy. Misuse may cause serious injury or death. Eye protection designed for paintball use must be worn by the user and any person within range. It is to be used by adults only. It is to be used on safety certified fields only. Obey all local, state and federal laws. Follow the rules of safe paintball gun handling. Read all instructions before use.

Defiant OVERVIEW

The *Defiant* is a quality marking instrument specially designed to meet the needs of the professional style tournament player. The *Defiant* is a electronic solenoid actuated computer controlled marking device. The major components of the *Defiant* are CNC machined from solid, aircraft-grade aluminum, then hard anodized per military specifications. No castings or stamped parts are used in the construction of the *Defiant*, thereby providing the end user with a high-quality, precision-engineered marking instrument.

Paintball markers get alot of abuse. Indian Creek Design, Inc., has built the *Defiant* with this in mind. All internal parts, wear and contact surfaces have been heat treated or hard anodized. The toughest and most resilient materials and components have been used in the design of this instrument.

The *Defiant* uses a single standard 9 volt battery for operation. The circuitry is a micro-processor based digital controller.

The *Defiant* does not need tools in order to field-strip it. Removing the field-strip link-pin of the bolt enables the removal of the entire bolt assembly.

The *Defiant* offers "low-pressure" operation. The main operating pressure is 225-275 PSI adjusted to visually via the gauge on the primary regulator. The secondary pressure is factory pre-set and regulated to 85-95 PSI. Gas usage is controlled through these 2 internal regulators. This is the only means of adjustment. The unique feature of this gun is the regulator adjustment. This allows precise adjustment for the velocity control of the gun and for gas efficiency.

The *Defiant* comes with 15/16-20, typically referred to as "Autococker*" type threads on its removable barrel system. This feature allows the user to select a barrel that is most suitable for the playing conditions.

* Autococker is a brand name owned in whole by Worr Games Products

OPERATION

Read the entire manual before you prepare your *Defiant* for firing. Safety and safe gun handling are the most important aspects of paintball sports. Please practice each of the following steps with an **unloaded** gun before attempting to charge your gun with compressed air and paint pellets. Do not load compressed air and paint pellets into your *Defiant* until you feel completely confident with your ability to handle your *Defiant* safely.

Keep your finger out of the trigger guard and away from the trigger; point the muzzle of the gun in a safe direction at all times. Keep the gun turned off until ready to operate. The *Defiant* does not have a mechanical safety, only an on-off switch! **Always keep your *Defiant* pointed in a safe direction. Always use a barrel plug.**

Installing the 9 volt Power Source

The *Defiant* requires a single 9 volt battery supply as the electronic power source. The use of long life batteries is recommended.

The 9-volt battery is located in the frame (or "tray") above the trigger and on-off switch. Before removing the tray, remove the grip frame side panel on the left side, exposing the CPU and switches. Note the blue wires looped down into the PCB cavity. This loop is to allow the necessary distance between the tray and upper body to change battery. This loop must be maintained when re-assembly is completed. To remove the tray use a 7/64 allen wrench and remove the four 6-32X1" screws around the bottom of the "tray". Gently separate the upper section from the lower section, being careful not to put stress on the wiring harness (blue looped wires) connected to the solenoid valve on the upper section. Place the battery into the terminal connector and with the wires in the down-ward direction place the battery and terminal into the tray, sliding them ALL of the way toward the front of the tray. Place the tray and upper body together being careful not to pinch any wires in the body, bring the blue wire loop back to its original position. Turn the main on-off switch to the on position and be sure the LED lights up, then turn off. Replace the four 6-32X1" screws and the grip panel.

CO2, Nitrogen or Compressed Air Usage

The *Defiant* comes with a male quick-disconnect adapter on the input side of the regulator. The *Defiant* can be set up to use a nitrogen or compressed-air system. CO2 is NOT recommended for use as the propellant, although it may be used. Be aware that under the conditions of CO2 the results may not be as expected. Consult the place where you purchased your *Defiant*, or a recognized and competent airsmith, for instruction in the safe handling of compressed-air cylinders before purchasing or connecting one to your *Defiant*. The input pressure from your compressed air system should be regulated down to 350-500 PSI output pressure. If your compressed air system does not have an output pressure gauge on its regulator we do not recommend its use.

REMEMBER CO2, compressed-air or nitrogen systems can be extremely dangerous if misused or improperly handled. Use only D.O.T. certified tanks.

Before pressurizing your *Defiant*, check to make sure that you have a barrel plug in place and there is no paint in the gun. The on-off switch should be OFF. Air can now be applied, the gun will become pressurized.

Paintball and Loader Usage

The *Defiant* comes equipped to accept 1.05" OD, standard-gravity feed loaders. Fit the loader directly into the vertical feed tube. Always twist it down in a CLOCKWISE direction. Always twist it off in a CLOCKWISE direction as well. The *Defiant* uses .68 caliber, water-soluble paint pellets. The pellets are gravity fed from the loader through the direct vertical feed nipple and into the breech of the gun.

DIP Switch settings - Modes - Rate of Fire -

Rate of fire is dependant on the mode and switch settings of the DIP switches on the PCB. Modes are :

1. semi-auto (one single shot per trigger pull),
2. 3 shot (3 shots if the trigger is pulled and not released, with single shot capabilities)
3. 6 shot burst (6 shots if the trigger is pulled and not released, with single shot or any amount between capabilities)
4. Full auto (as long as the trigger is pulled it will cycle)

Mode selection is done via switches #1 and #2. Mode settings using the switches are as follows:

#1	#2	
off	off	Semi mode
on	off	3 shot mode
off	on	6 shot burst mode
on	on	Full auto mode

Rate of Fire and timing is as follows:

Dip switch #3 and #4 (registers Solenoid on times in milliseconds)

#3	#4	
off	off	= 06 ms
on	off	= 08 ms
off	on	= 10 ms
on	on	= 12 ms

Dip switch #5,#6 and #7 (registers Solenoid off (delay before re-cycle) times in milliseconds)

#5	#6	#7	
off	off	off	= 70 ms
on	off	off	= 80 ms
off	on	off	= 90 ms
on	on	off	= 100 ms
off	off	on	= 110 ms
on	off	on	= 120 ms
off	on	on	= 130 ms
on	on	on	= 140 ms

Dip switch 8 is slated for an LCD usage to display mode, cycle rate and shot count.

on = display yes
off = display no

As you see, calculating the cycles per second is easy and precise. For instance, if S3 is off & S4 is on, S5 & S6 are off and S7 is on the rate is calculated as $.010 + .110 = .120$. A total of cycle times of $.120 = 8.33$ cycles per second (1 divided by $.120$).

This is the calculation for semi-auto Cycles Per Second mode.

3 shot, 6 shot, and full-auto cycle rates are adjusted to meet the paintball industries

rate of fire maximum requirements. To calculate CPS for 3,6, and full, simply multiply the switch settings for #5, #6, and #7 by 1.5.

(ie # 5 # 6 # 7
(off off off = 70 ms) $70 \text{ ms} \times 1.5 = 105 \text{ ms}$)

example: if #3,#4,#5,#6,#7 are all switched off (which is the fastest cycle rate in any case) then the calculation would be as follows

$.07 \times 1.5 = .105$

$.105 + .006 = .111$

1 divided by $.111 = 9.00$ Cycles Per Second

Firing the Defiant

Keep your finger out of the trigger guard and away from the trigger; point the muzzle of your gun in a safe direction at all times during this process. Be sure your goggles are securely in place. Push the on-off switch into the off position.

Always keep your Defiant pointed in a safe direction!

1. Place the empty loader onto the gun. Be sure that it is securely mounted in place.
2. Apply the compressed gas, pressurizing the gun.
3. Put the paintballs into the loader.
4. Remove the barrel plug.
5. Aim the gun at the target.
6. Push the on-off switch to the ON position, the LED will light up.
7. Place your finger on the trigger.
8. Pull the trigger with a smooth squeezing motion. **BANG....**

UNLOADING THE Defiant

Keep your finger out of the trigger guard and away from the trigger; point the muzzle of your gun in a safe direction during this entire process. *Always keep your Defiant pointed in a safe direction!*

1. Push the on-off switch to the off position the LED will be off.
2. Place the barrel plug into the end of the barrel.
3. Remove the pressurized gas from the marker carefully.

NOTICE IS HEREBY GIVEN THAT THIS DRAWING IS PART OF THE ARTICLE OWNED IN WHOLE BY INDIAN CREEK DESIGN, INC., KNOWN AS INDICATED ON THE DRAWING AND ALL RIGHTS OF MANUFACTURE AND REPRODUCTION OF SUCH ARTICLES OR ANY PART THEREOF IS RESERVED BY INDIAN CREEK DESIGN, INC., AND NEITHER SAID ARTICLE NOR ANY PART THEREOF MAY BE MANUFACTURED OR REPRODUCED EXCEPT BY WRITTEN AUTHORIZATION FROM INDIAN CREEK DESIGN, INC. ALL PROPRIETARY RIGHTS AND INFORMATION ARE THE SOLE PROPERTY OF INDIAN CREEK DESIGN, INC.

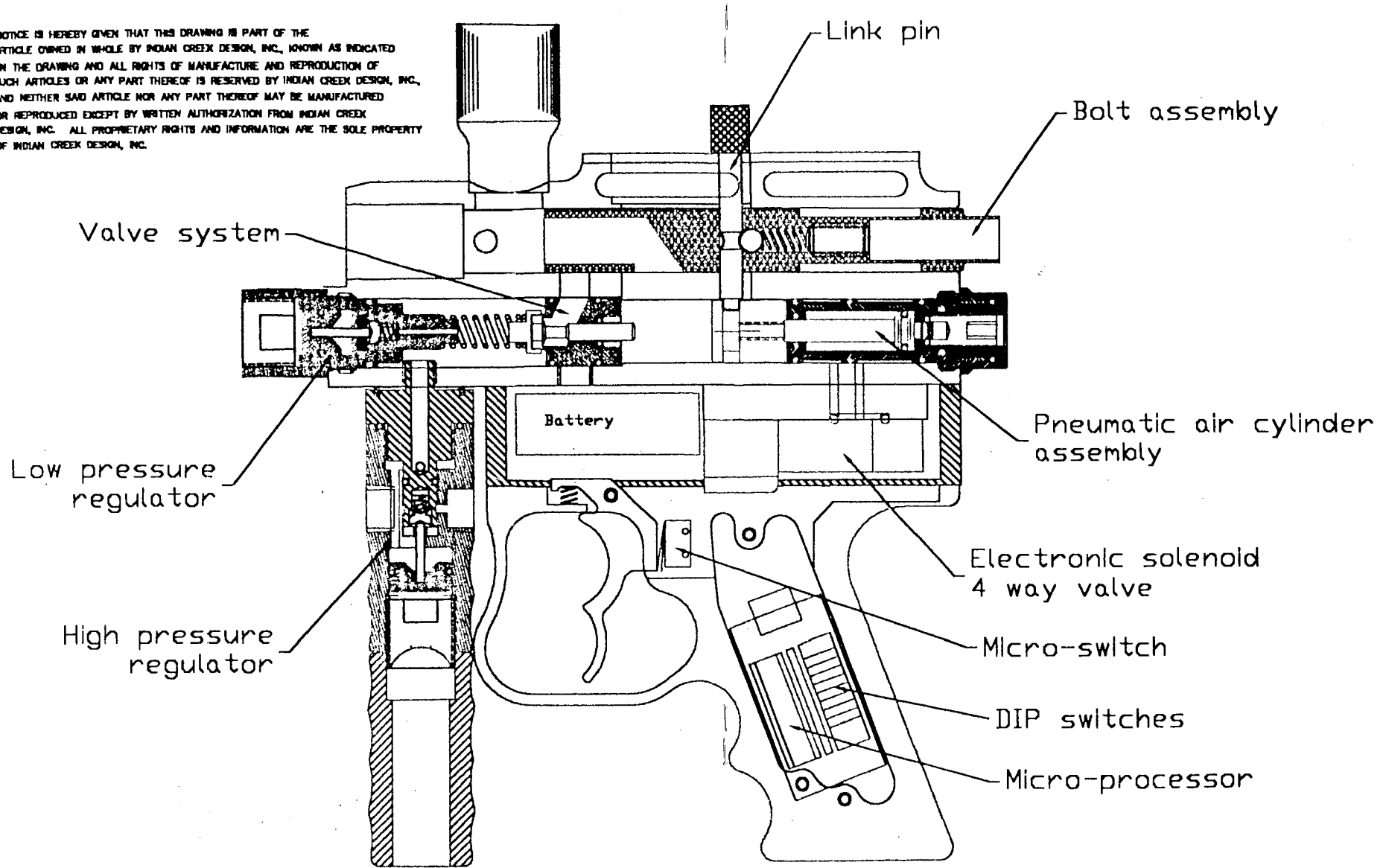

4. Tilt the marker so that the loader is lower than the body of the gun.
5. Remove the paintball loader from the direct vertical-feed tube, turning the loader in a clockwise direction.
6. Inspect the inside of the direct vertical-feed tube to be sure that a ball does not remain inside the breech.

MAINTENANCE

CAUTION: Before attempting to perform any maintenance operations or any gun disassembly, make sure that *all* paint pellets and sources of propellants have been removed from the gun. Insert a barrel plug, push the on-off switch to the OFF position and keep the gun in its "SAFE" mode.

Simple Maintenance

Keep your *Defiant* clean and lubricated to eliminate the friction that would prevent reliable operation. Clean and lube the gun before each use, and do not put it away dirty. Do *not* use petroleum-based lubricants in the lubrication of this gun. Teflon or silicon spray lubricants are the recommended types for the lubrication of the *Defiant*. The main housing bolt slide area may be lubricated.

Cleaning Paint from the Barrel

Unscrew the barrel with approximately one and one half (1-1/2) revolutions to remove the barrel for swabbing/cleaning. Keep the barrel clean to insure the continued accuracy of the *Defiant*. Gelatin from the paintballs has a tendency to build up in the barrel. As part of your cleaning ritual, wash out the barrel with hot soapy water and rinse it well.

Removing the Bolt Assembly (Field Stripping)

Remove the paint and pressurized gas from the gun. *The gun can be field stripped while it is pressurized.*

1. Remove (pull) the knurled pin from the top of the marker. Pull the bolt body out the back of the main body.

Once the bolt assembly is removed, it is possible to clean the entire upper receiver of the gun, including the breech and feed tube area. You may slightly lubricate the

rear section of the bolt and bolt chamber with a light synthetic liquid or spray lubricant before re-installing the bolt. Do *not* use petroleum/oil-based lubricants; *do* use Teflon or silicon-based lubricants. The "bolt" is *NOT* a simple plastic, it is a natural Delrin acetate material which is a Dupont 3M material developed specifically for this type of application. *The use of a metal type of bolt will void all warranties.*

1. Point the barrel downward and slide the bolt in until the link pin hole lines up with the slot in the hammer and install the link pin

STORAGE AND TRANSPORTATION

- Your *Defiant* must be clear of all paint and propellant when not being used.
- Be sure the on-off switch is off and the LED is not lighted.
- Put the barrel plug in place.
- Make sure the gun is clean.
- Store your *Defiant* in a clean, cool, dry place.
- Keep your *Defiant* away from children.

This air gun is not a toy! To be used by adults only!

Your *Defiant* must be clear of all paint and any source of propellant during transportation to and from the playing field. Keep your barrel plug in place. Keep the on-off switch off. Protect your *Defiant* from excessive heat during transportation. Observe and obey all local, state and federal laws concerning the transportation of paintball guns. For information concerning any of the laws in your area, contact your nearby friendly law enforcement agency.

IMPORTANT: Never carry your *Defiant* uncased when not on a playing field. The non-playing public and law enforcement personnel may not be able to distinguish between a paint marking device and firearm. For your own safety and to protect the image of the sport, always carry your *Defiant* in a suitable gun case or in the box in which it was shipped.

If you must ship your *Defiant* for any reason, the box in which you purchased the gun is acceptable to all major carriers. Never ship charged CO2 or pressurized gas containers.

Defiant TUNING GUIDE

High pressure regulator adjustment:

The *Defiant* has a totally new and innovative system. The pressurized gas is regulated internally. The pressure regulator is externally adjustable via the screw with the slot in the bottom of the high-pressure regulator. A cap for this screw has been provided to keep access to this screw restricted. To increase the pressure, thus increasing the velocity of your projectile, remove the cap. Using a wide screw driver, or even a Quarter insert into the slot and turn clockwise.

NOTE: Only slight turns are needed to accomplish changes in the pressure used to shoot the paintball, thus changes in the velocity at which it is propelled.

To decrease the velocity of your shots, turn the screw counter-clockwise. You must take a "clearing" shot before the change in the decreasing direction can be registered.

A pressure gauge has been installed into the regulator body to indicate the exact operating pressure of the marker. This gauge is extremely useful. At the factory we set the regulator gauge to 225-275 PSI with a input pressure of 400 PSI using Compressed air as the base propellant. Under normal circumstances these settings will produce paintball velocities at approximately 280-300 fps. The input pressure from your tank should be set at 350-500 PSI. Higher input pressures will not provide increased performance.

Low pressure regulator adjustment:

The low pressure regulator is externally adjustable via the adjustment screw with the two small 1/8" diameter holes in the front of the low-pressure regulator. The low pressure regulator is pre-set at the factory to 85-95 PSI to operate the 4-way solenoid actuated valve. It may be necessary to re-adjust the low pressure regulator from time to time. Bench adjusting the regulator can be done by pressurizing the gun and then turning the adjustment screw inward (clock-wise) until you hear a leak coming from the 4-way valve. The 4-way valve has an over-pressurization relief valve that will start to bleed off at approximately 125 PSI, once you hear the leak start then back off the adjustment screw 1/2 turn and the leak will stop and that will approximate the pressure to about 90 PSI.

This gun was designed with safety and safety standards in mind. If you attempt to shoot paintballs higher than established safety standards, the gun will not function properly.

NOTE 1. You may notice that if you attempt to operate the gun at extremely high velocities, the internals will not function properly!

NOTE 2. This gun is not designed to shoot above the safety limits established by industry standards.

Leak Related Problems

1. **The *Defiant* has a leak down the barrel. Reason: gas is leaking through or around the valve pin seal or O`ring area.**
 - a. Can you hear the leak when the gas is removed? Yes? There is no leak. You hear the ocean.
 - b. The valve seal is marred/scratched or worn out or dirt has gotten to it. Replace it.
2. **The *Defiant* has a leak around the high pressure regulator seam. Reason: the seal between the regulator body and the main body is bad.**
 - a. Tighten the regulator to the body.
 - b. Check and/or replace the O`ring.
3. **The *Defiant* has a leak around the low pressure regulator seam. Reason: the seal between the regulator body and main body is bad or the regulator has loosened up.**
 - a. Tighten the regulator into the body.
 - b. Check and/or replace the O`ring gasket. Sized -019.
4. **The *Defiant* has a leak inside the grip/battery area. Reason: the 4 way valve is leaking.**
 - a. Tighten the 4 way valve to the manifold.
 - b. Check for over-pressurization from the low pressure regulator.
 - c. Replace the O`rings on the cylinder assembly. Sized -015.
 - d. Replace the piston O`ring. Sized -011
 - e. Replace the solenoid/valve assembly.

Ball Breakage Problems

1. The ball breaks in the breech.

- a. The balls in your loader can bind, messing up your trigger timing. Note the ball drop, use an agitated loader.
- b. As you **run and shoot**, you actually **unweigh** the gravity-fed balls in your loader. This can cause a ball to hesitate in its drop. This affects your trigger timing.
- c. If the ball retention ball does not move freely, the paintballs will crush against it or it may have stuck in the depressed position allowing double feeding. Check its tension regularly and keep this area as clean as possible.
- d. If the ball retention ball is too sloppy, the ball will not be held in the proper position. This may allow the next ball to enter the path of the bolt, subjecting it to impact cracking or shearing. Verify the tension.
- e. Increasing the timing of the solenoid on time will decrease the possible blow-back that is created when the ball is expelled, or increasing the solenoid off time to increase the time that the bolt stays back to let another ball drop into the breech.

Regulator Related Problems

1. The gauge reads correctly when charged, but climbs in pressure after a few moments.

- a. The regulator seal has been contaminated. Disassemble the regulator, and clean the seal with a “Q-tip” and alcohol. If you need assistance in the disassembly of the regulator, please call (208)468-0446.

2. The gauge reads correctly when charged, but drops in pressure after a few shots.

- a. The regulator may not be adjusted correctly. Remove all pressurized gas, and back-off the regulator adjustment screw 3 turns. Pressurize the system and adjust the pressure back up to the desired pressure.

3. The gauge reads correctly when charged, but drops in pressure after a few shots, and is slow to climb back to normal pressure.

- a. The recovery side of the regulator is sluggish and may need cleaning and lubrication. If you need assistance in the disassembly of the regulator, please call (208)468-0446.
- b. The regulator seal needs to be replaced if it has a deep groove in it from the regulator cup.